

## **Before You Start**

- Check the pack and make sure you have all of the parts listed above. When you are ready to start, make sure that you have the right tools to hand, plenty of space and a clean dry area for assembly.
- Check that parts are present and undamaged before assembling the unit.
- Hardware parts are usually packaged inside a cardboard wrap often located at one end of the carton. Do not discard carton material until you are certain all parts and hardware are present.
- Separate hardware into groups of identical parts for easier identification during assembly.
- Please assemble your furniture on the box it came in to prevent scratching the unit.
- For large units you will need another person to help you with the assembly.
- As with all fine furniture, do not place either hot or cold containers on the surfaces.

## **Assembly**

- It is not recommended to use power tools when assembling this product.
- Every product has been thoughtfully engineered for ease of assembly and manufactured with computer-aided precision. All bolts, screws and connectors should be retightened after two weeks use.

## **Care & Use**

- Wipe clean with a soft damp cloth. Never use scourers abrasives or chemical cleaners.
- As with all furniture pine can be damaged by knocks and scrapes. If you dent the surface or break the seal of the lacquer, rub some solid wax into the dent to exclude atmospheric moisture. Use candle wax for the wooden runners, to allow smoother running.
- Pine is a totally natural material therefore no two pieces are ever identical in pattern or color. Over time, solid wood will darken and mellow, a process that will enhance the beauty and warmth of your furniture as it ages. Exposure to direct sunlight will hasten this process. As a result new pieces may look a shade difference to those you already have. This variation is normal and the color difference will diminish over a short period of time. Similarly, areas that have been concealed for some time by a lamp or vase, for example, will likely be lighter than the surrounding areas. To minimize these differences, it is recommended that lamps and other decorative items be moved periodically so that the aging process will be equalized. Also take care not to subject your furniture to extreme heat like radiators etc, or steamy rooms.

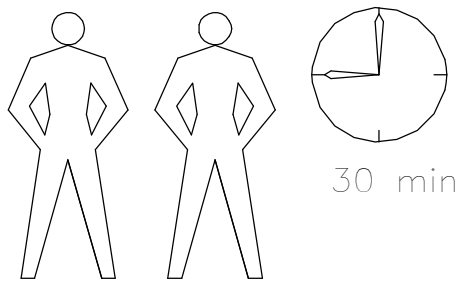

Tools needed (not supplied)

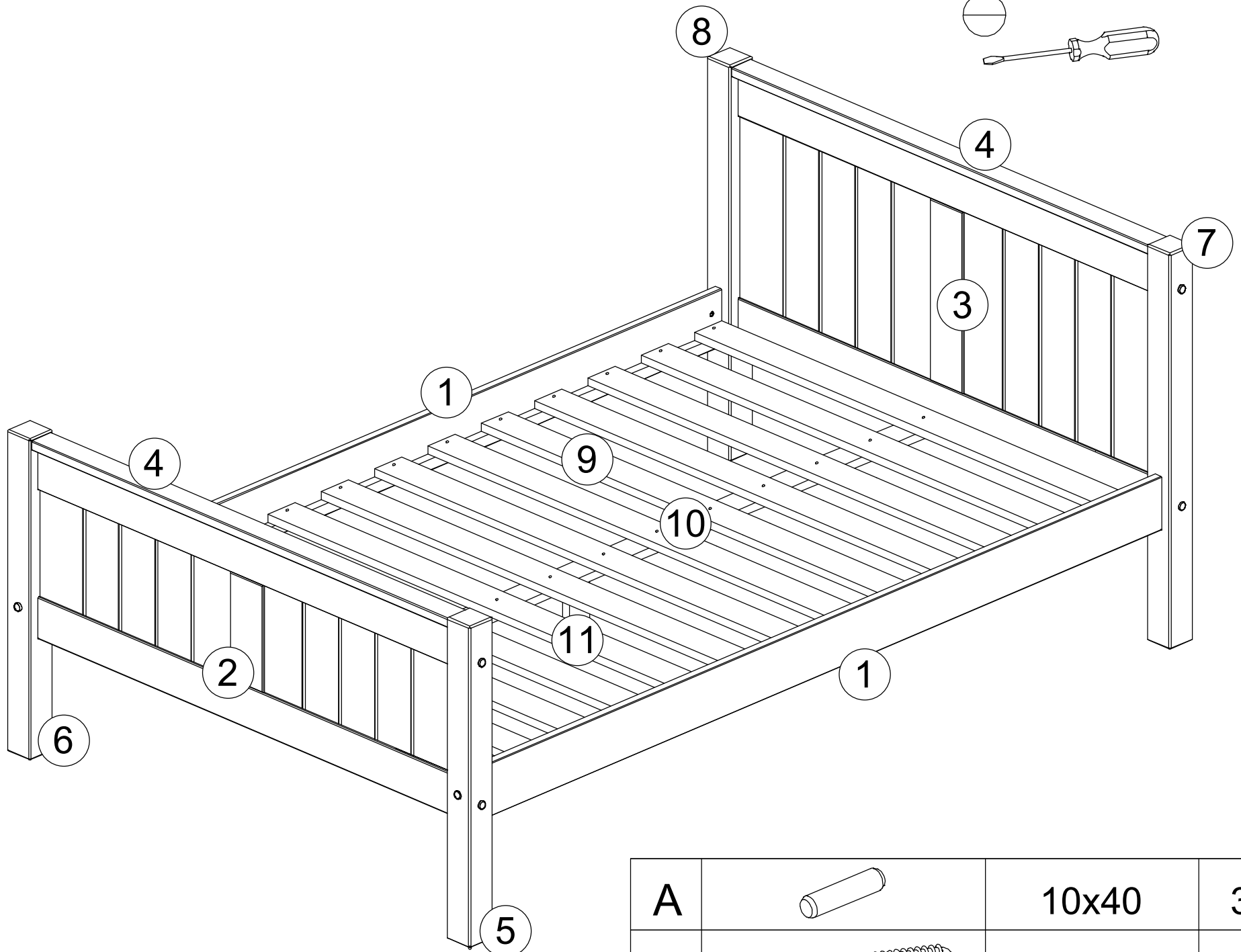
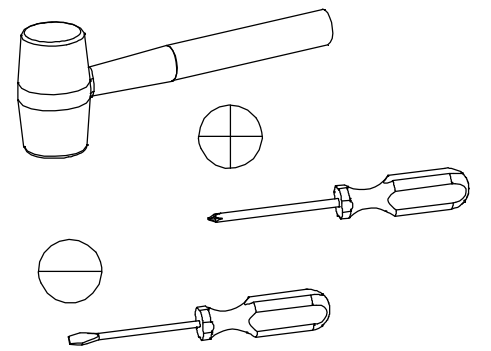

## IMPORTANT

Before you begin, please read the assembly instructions carefully. Follow it step by step.

Mattress of 120x190 cm is recommended.

The bed should not be used if any structural part is broken or missing.

A		10x40	31
B		6,3x100	8
C		M6x110	4
E		M6x10x13	4
H		7x50	1
I		3,5x35	42
N		D15	12
O		GLUE	1
P		4mm	1
Q		68x20x20	2
X		3,5x16	8
Y		40x30x40	2

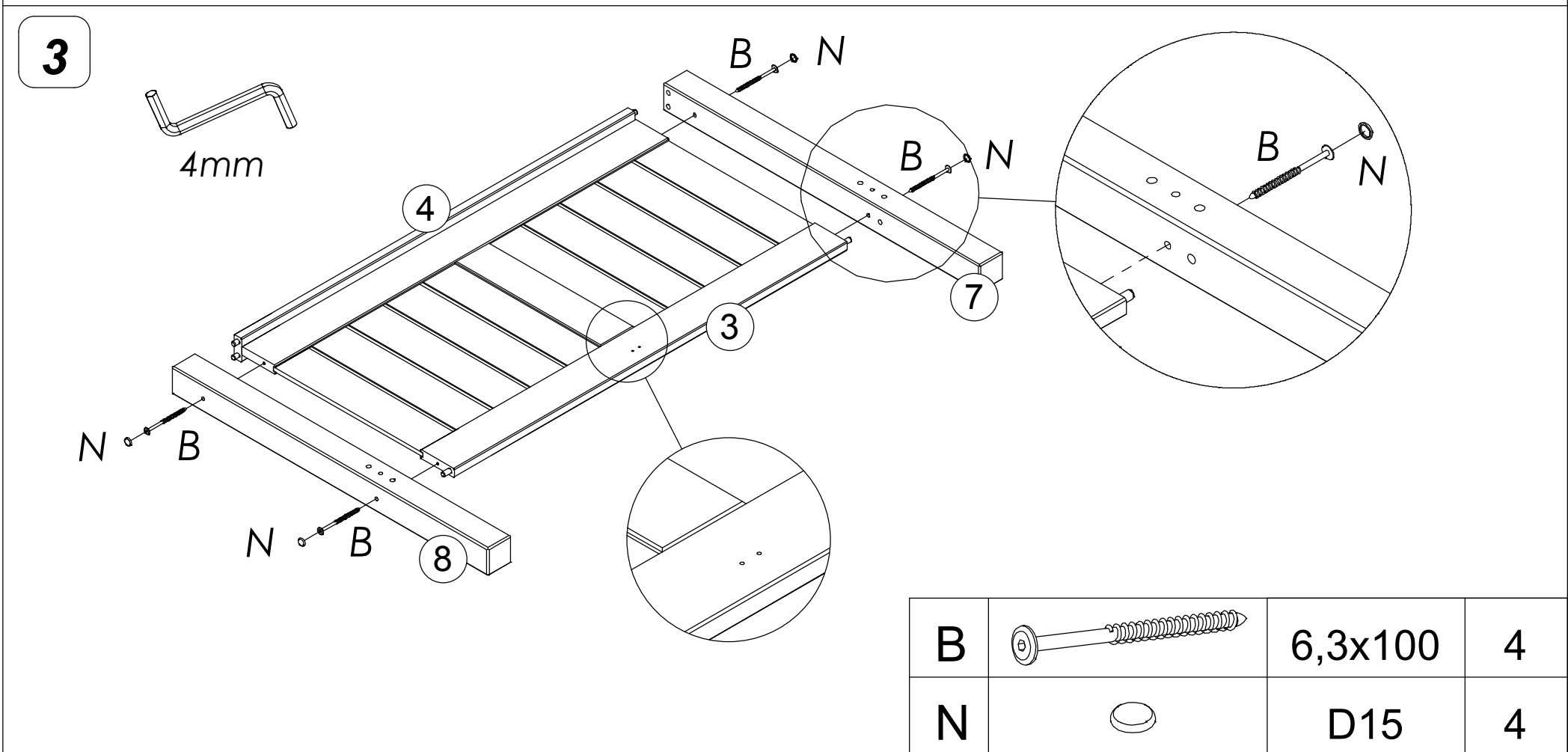
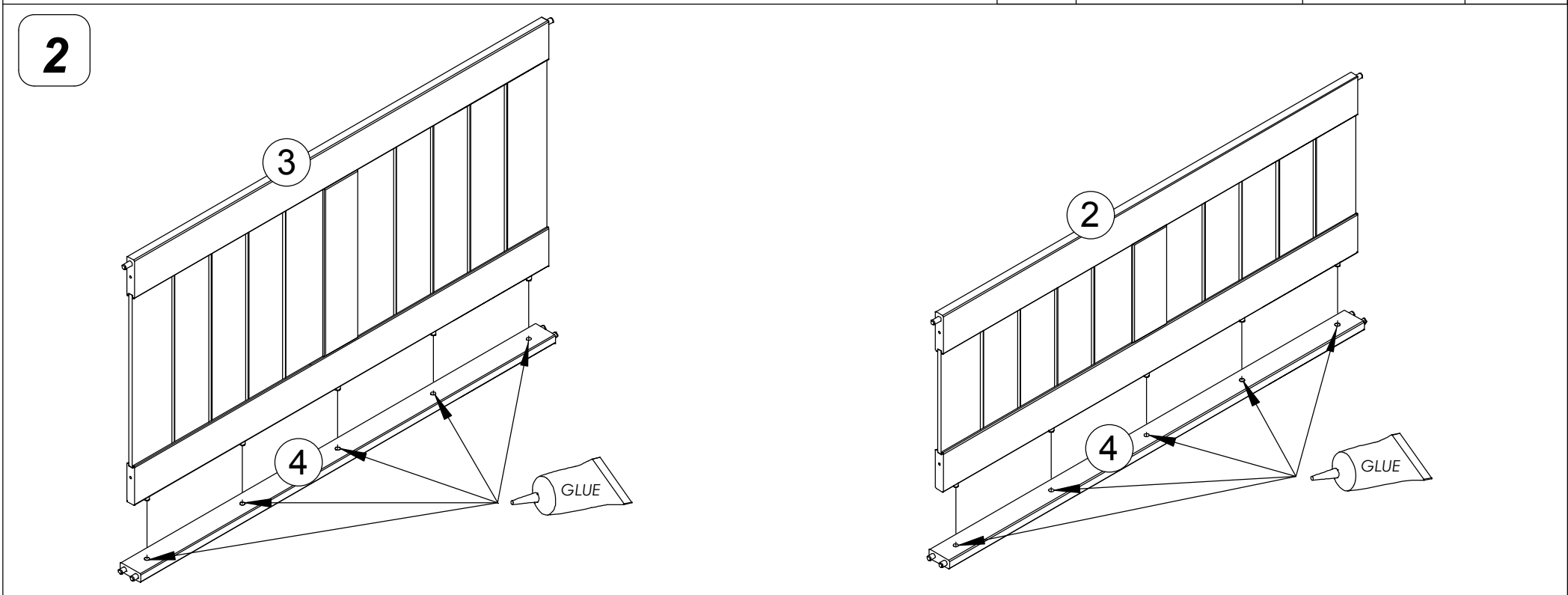
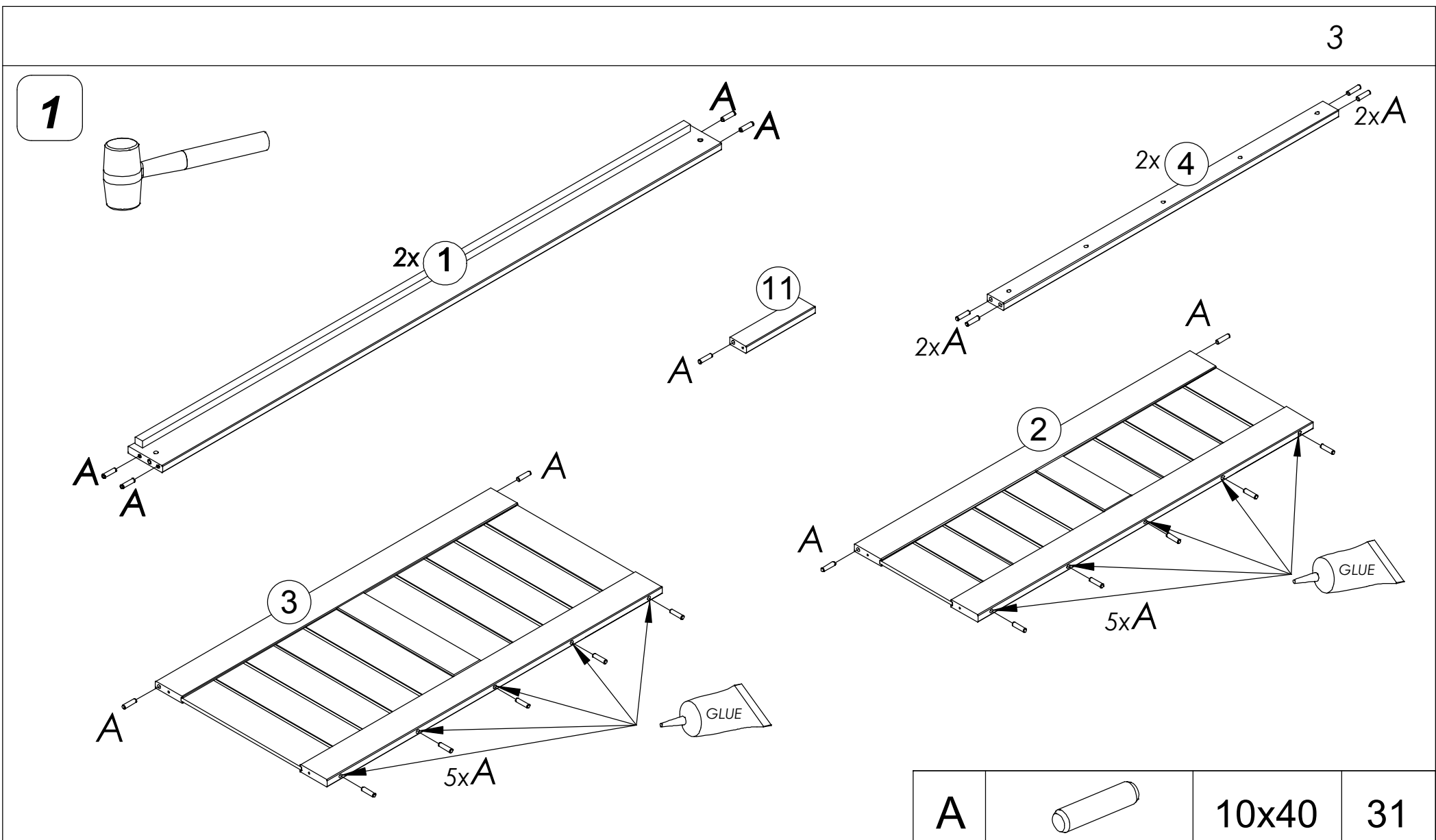

4

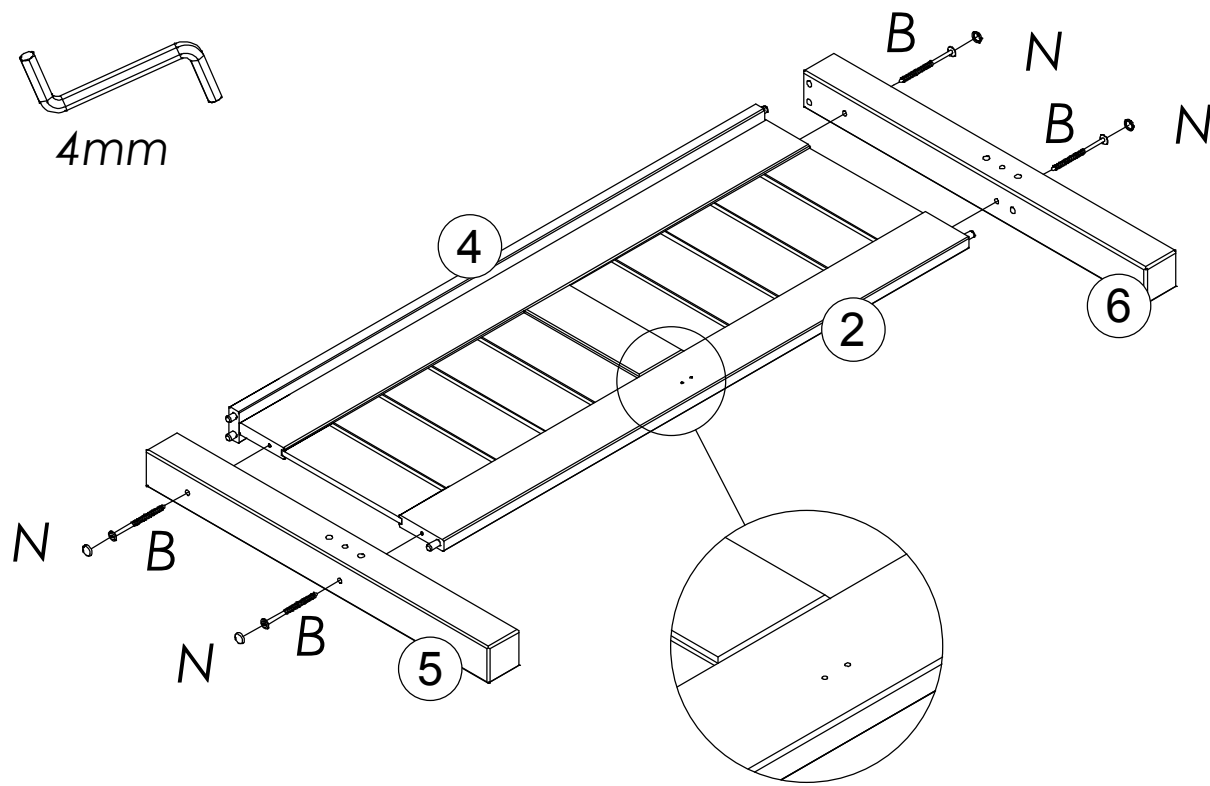
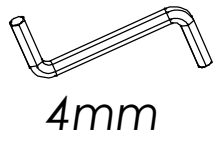

B		6,3x100	4
N		D15	4

5

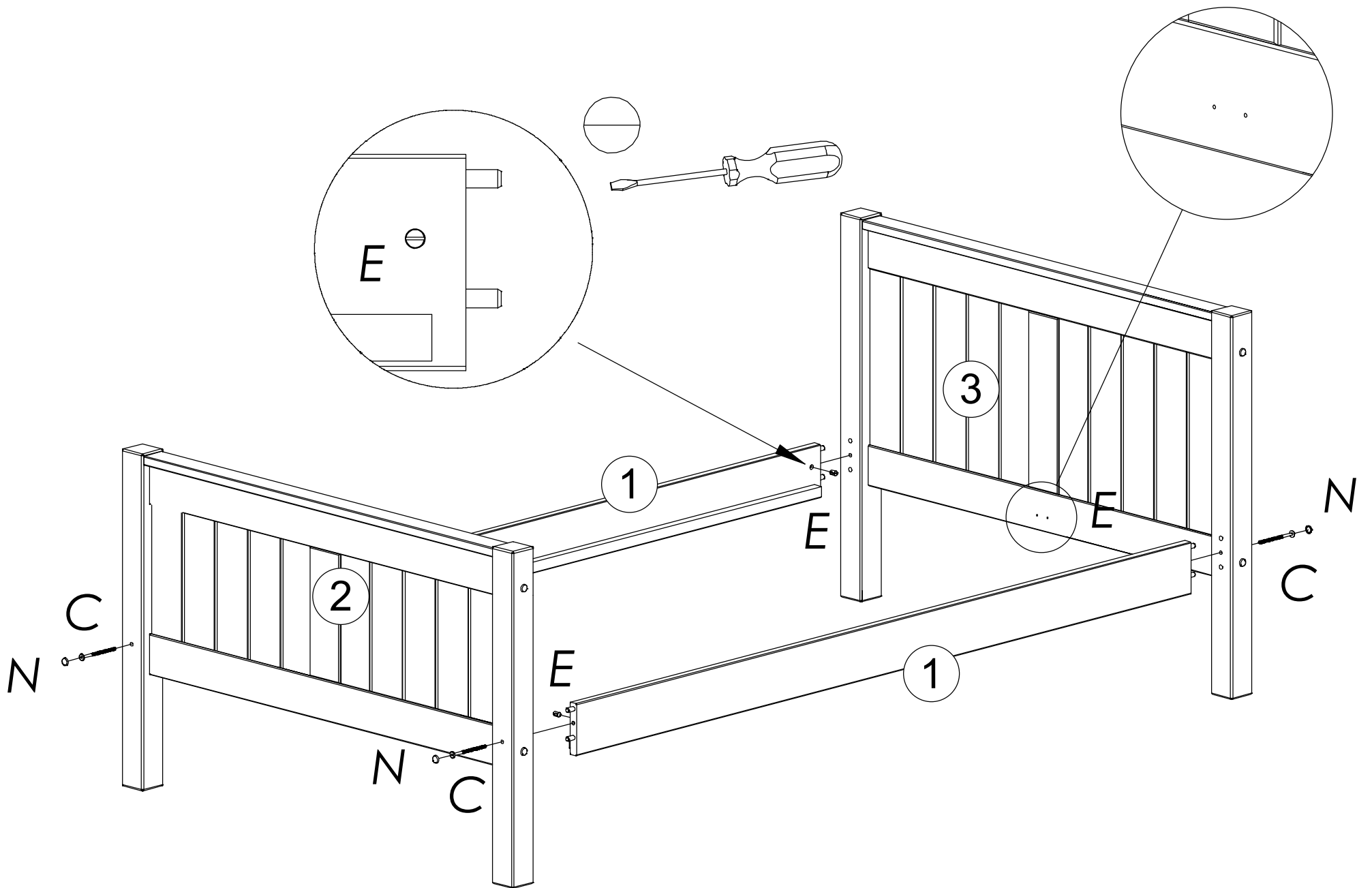
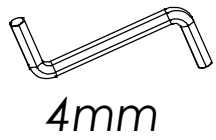

C		M6x110	4
E		M6x10x13	4

N		D15	4
---	--	-----	---

6

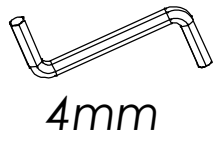

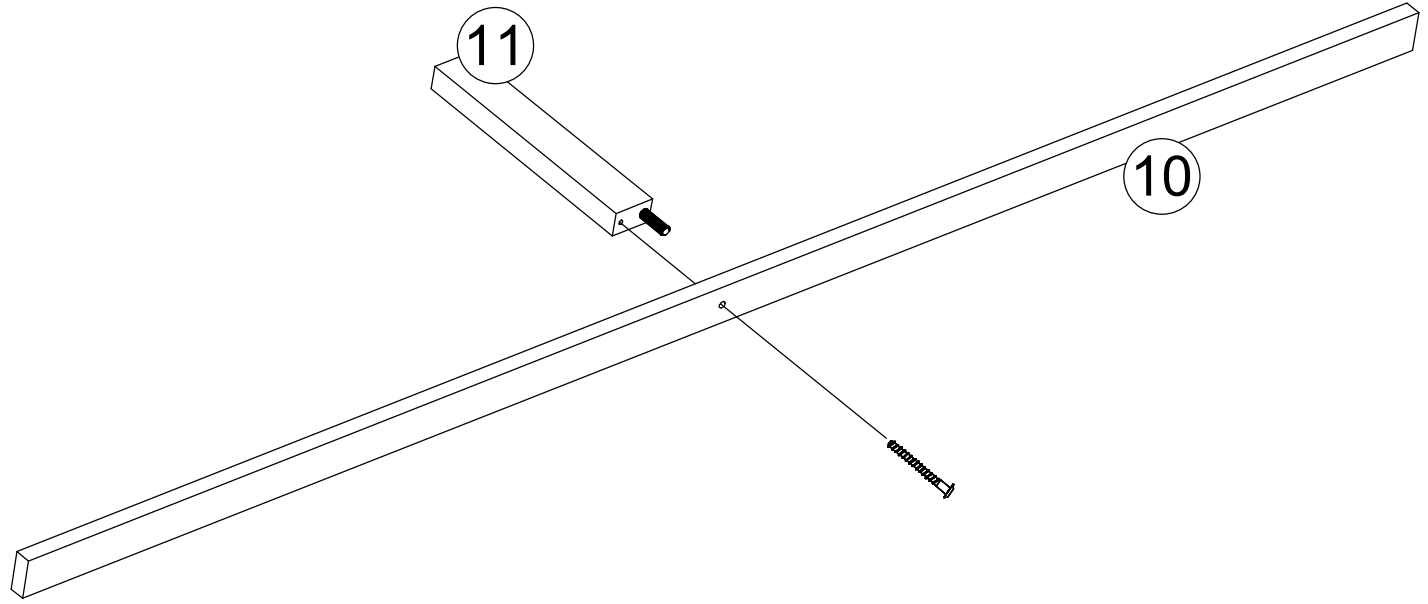

H		7x50	1
---	---	------	---

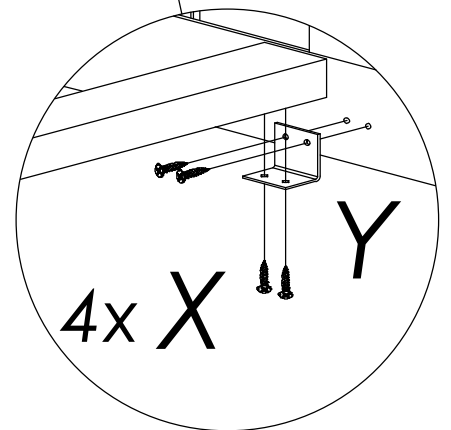
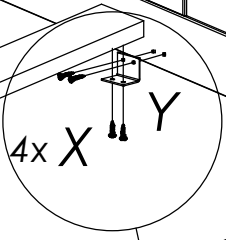
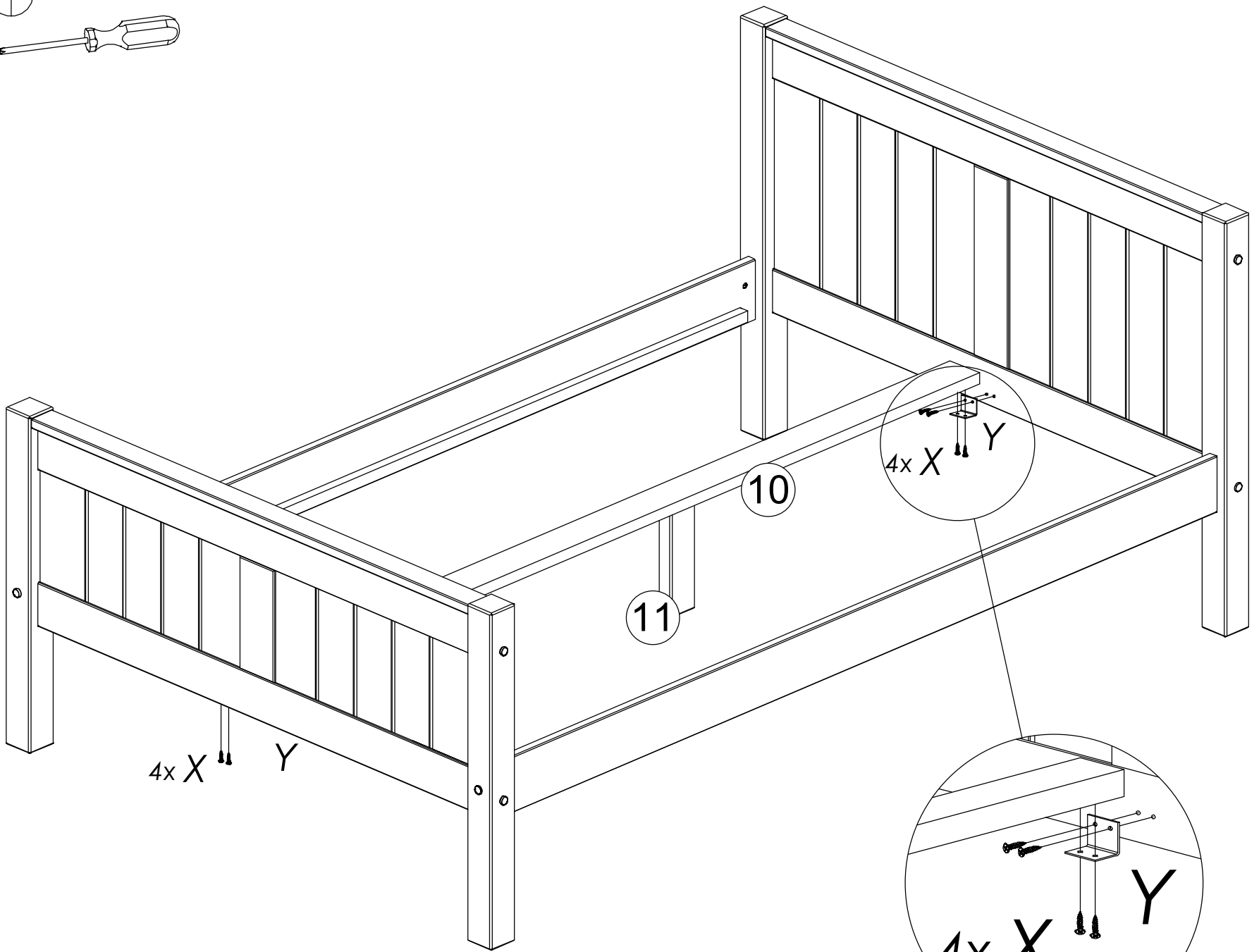
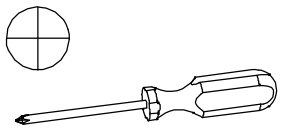

7

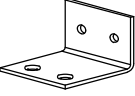

X		3,5x16	8
Y		40x30x40	2

I		3,5x40	42
Q		68x20x20	2

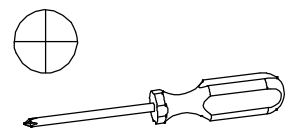

8

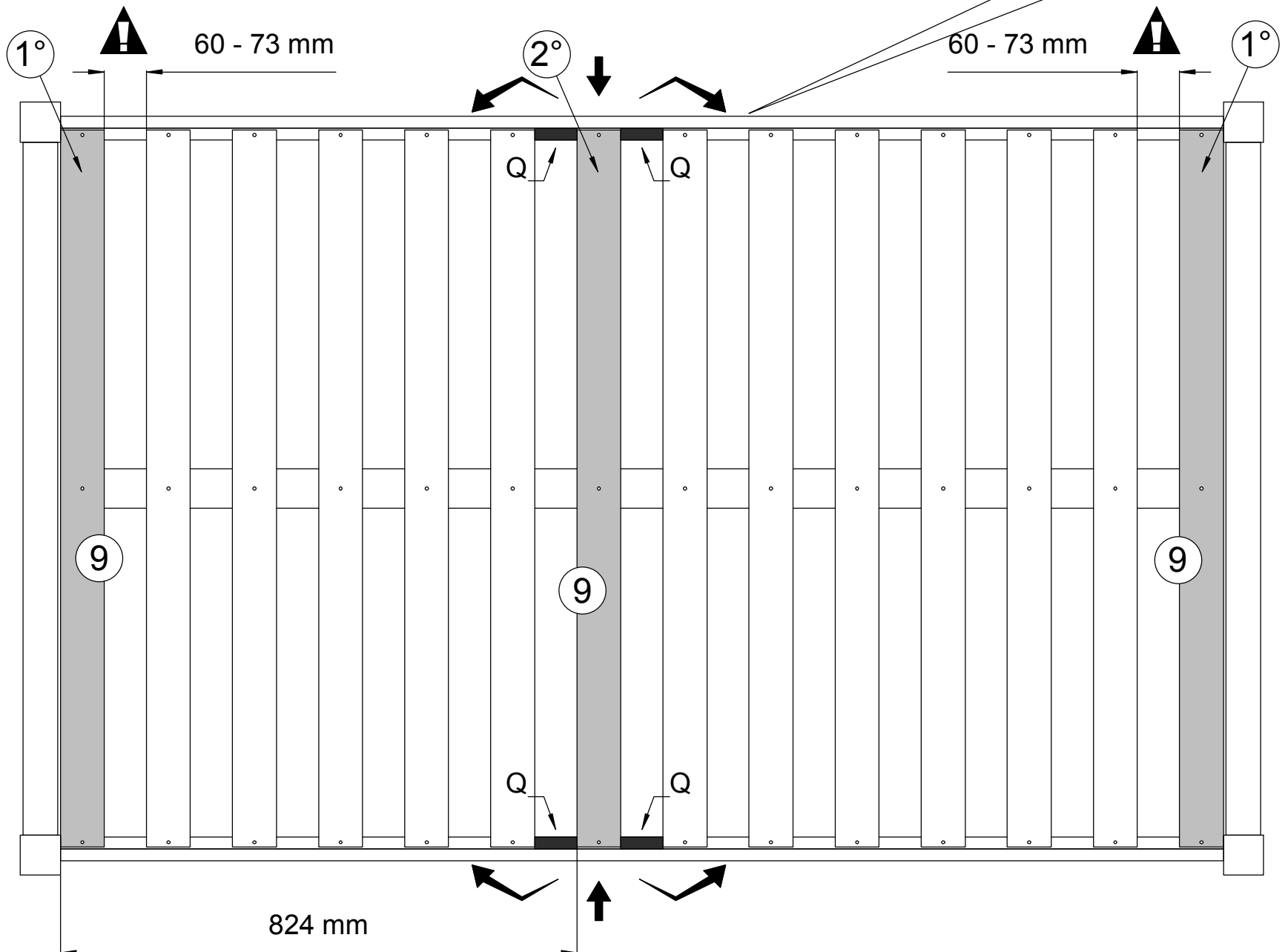
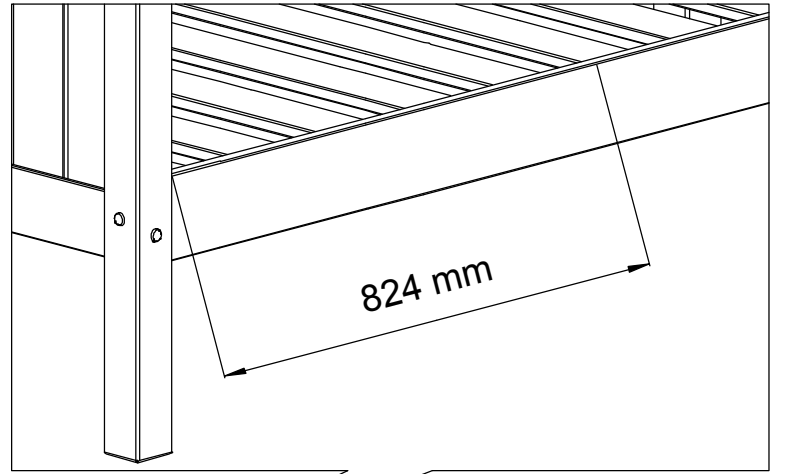
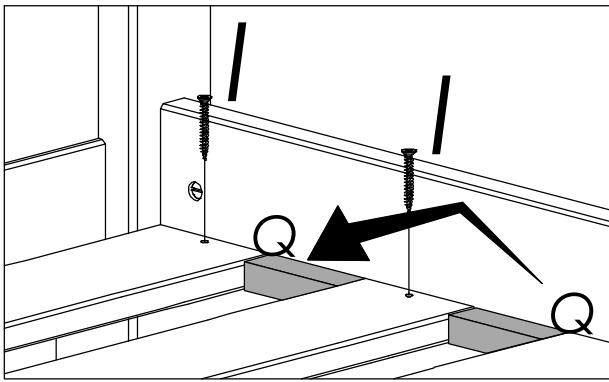
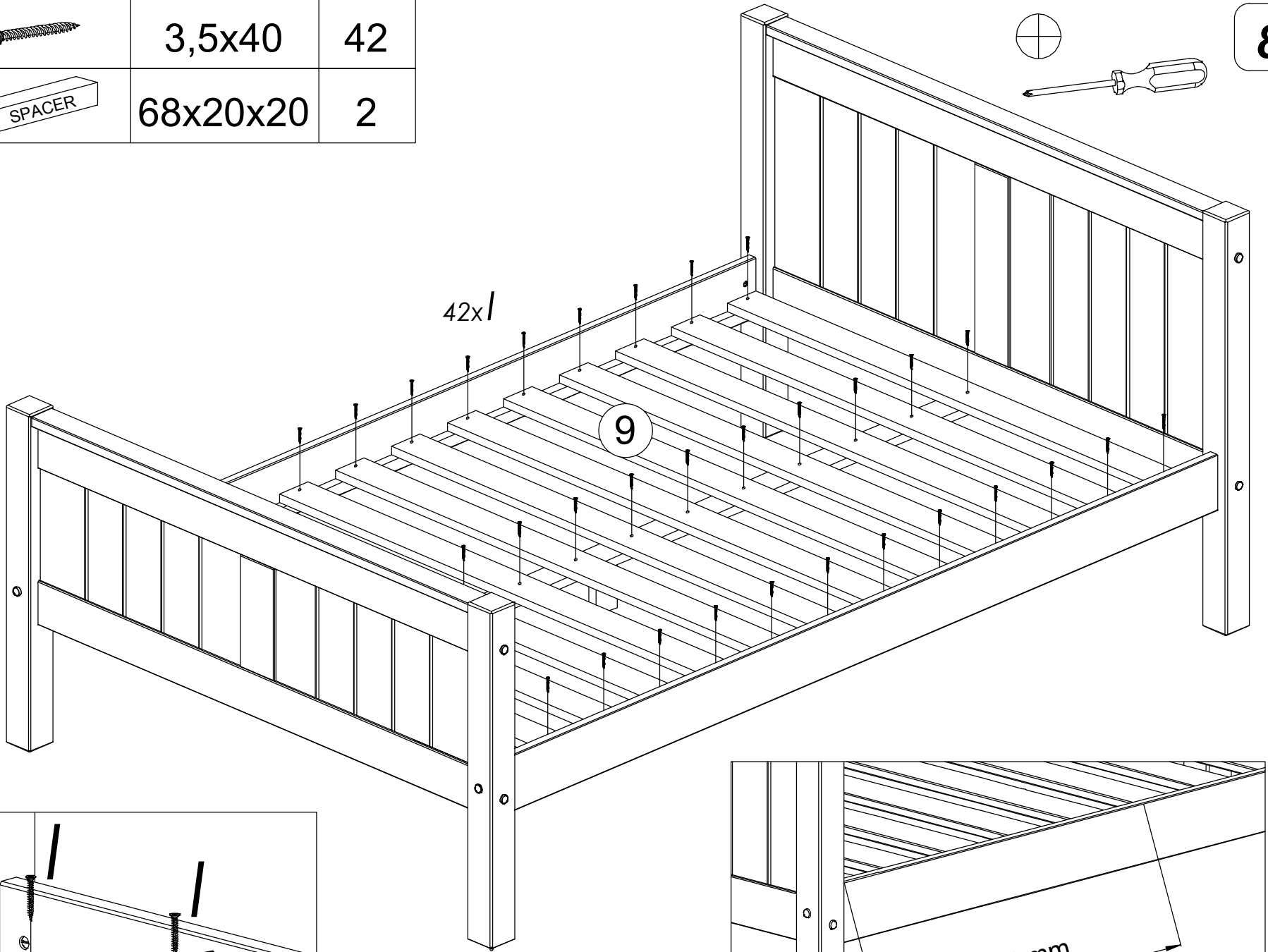

## Customer Notice

Dear Customer,

Congratulations on the recent purchase of your furniture!

Customer Service:

For missing or spare parts requests please contact us Monday to Friday – 10am to 3pm in one of the following ways:

Phone: 0844 8008475

[service@nordika.co.uk](mailto:service@nordika.co.uk)

Please inform: product, colour, where did you buy it, part no, quantity and reason for request. We need your full name, address and telephone number.

Fax: Please complete the enclosed Service Form and fax to 0560 1132071

By post: Please complete the enclosed Service Form and post to:

Nordika Design Ltd.  
High Rigg  
Panorama Drive  
Ilkley, LS29 9RA

We will do our utmost to supply spare parts within 7-10 working days of receipt of request.

Our quality control team has ensured a high quality product that we are sure you will be pleased with. All our furniture is produced from solid wood which contains knots and may have surface defects which are a feature of a natural product.

# Customer Service Form

Please return complete to:

Fax: 0560 1132071

Name: .....

Address: .....  
.....  
.....  
.....  
.....

Contact No: .....

Date of purchase: .....

Place of purchase: .....

Product Name: .....

See assembly instructions

Problem: .....  
.....  
.....  
.....

Parts Needed:	Part No.	Quantity	Description
<small>Please quote assembly instruction letter or number</small>			<small>e.g drawer base</small>
	.....	.....	.....
	.....	.....	.....
	.....	.....	.....
	.....	.....	.....
	.....	.....	.....